



Operation
&
Parts Manual

for

Box Blade Models

BB15-48, 60

BB20-48, 60, 72

BB30-60, 72, 84, & 96

Operations and Parts Manual

Table of Contents

Section	Page
Table of Contents	2
Retail Customer Responsibility	2
Manufacturer's Warranty	3
Dealer Preparation Checklist	3
Safety Precautions	4
Laws and Regulations	5
Attachment and Detachment	6
Operation and Adjustment	6
Transport	6
Maintenance	6
Torque Specifications	7
Parts List	8

BECAUSE THE MANUFACTURER MAINTAINS AN ONGOING PROGRAM OF PRODUCT IMPROVEMENT, WE RESERVE THE RIGHT TO MAKE IMPROVEMENTS IN DESIGN OR CHANGES IN SPECIFICATIONS WITHOUT INCURRING ANY OBLIGATION TO INSTALL THEM ON UNITS PREVIOUSLY SOLD. BECAUSE OF THE POSSIBILITY THAT SOME PHOTOGRAPHS IN THIS MANUAL WERE TAKEN OF PROTOTYPE MODELS, PRODUCTION MODELS MAY VARY IN SOME DETAIL. IN ADDITION, SOME PHOTOGRAPHS MAY SHOW SHIELDS REMOVED FOR PURPOSES OF CLARITY. **NEVER OPERATE THIS IMPLEMENT WITHOUT ALL SHIELDS IN PLACE.**

RETAIL CUSTOMER'S WARRANTY RESPONSIBILITY

It is the Retail Customer and/or Operator's responsibility to read the Operator's Manual, to operate, lubricate, maintain and store the product in accordance with all instructions and safety procedures. Failure of the operator to read the Operator's Manual is a misuse of this equipment. It is the Retail Customer and/or Operator's responsibility to inspect the product and to have any part(s) repaired or replaced when continued operation would cause damage or excessive wear to other parts or cause a safety hazard. It is the Retail Customer's responsibility to deliver the product to the authorized manufacturer Dealer, from whom he purchased it, for service or replacement of defective parts which are covered by warranty. Repairs to be submitted for warranty consideration must be made within thirty (30) days of failure. It is the Retail Customer's responsibility for any cost incurred by the Dealer for traveling to or hauling of the product for the purpose of performing a warranty obligation or inspection.

Manufacturer's Warranty

The manufacturer warrants each new implement to be free from defects in material and workmanship under normal use and service for a period of one year from the date of original sale.

This warranty is expressly in lieu of all other warranties and representations, expressed or implied, and all other obligations or liabilities on the part of the Manufacturer.

Manufacturer's liability and obligation is limited to repair or replacement of the product or a refund of purchase price, at Manufacturer's option, provided the purchaser returns the claimed defective product to the Manufacturer, or authorized distributor, with transportation charges prepaid, and an examination by Manufacturer discloses the product is defective.

This warranty does not cover said product which has been repaired or altered outside of the factory of Manufacturer in any way as to, in the judgment of the Manufacturer affect the stability, reliability or performance of the product. This warranty does not cover damage or product failure caused by accident, misuse, negligence, tampering, improper attachment or improper maintenance.

This warranty is null and void unless "Warranty Registration Form and Inspection Report" is completed and returned to Manufacturer.

This warranty excludes any and all liability for consequential or incidental damages.

This warranty gives you specific legal rights providing said product is put to its proper designed use.

THIS CHECKLIST TO REMAIN IN OWNER'S MANUAL

Dealer Preparation Check List

- 1. Assembly Completed
- 2. All fasteners torqued to specifications given in Torque Chart
- 3. All decals in place and readable
- 4. All guards in place and in good operating order
- 5. Overall condition good (paint, welds)
- 6. Operator's Manual has been delivered to owner
- 7. Owner has been instructed on the safe and proper use of the implement

Dealer Signature: _____

It is the dealer's responsibility to complete the procedures listed above before delivery of this implement to the customer.

IMPORTANT SAFETY PRECAUTIONS

In addition to the design and configuration of equipment, hazard control and accident prevention are dependent upon the awareness, concern, prudence and proper training of personnel in the operation, transport, maintenance and storage of equipment. Lack of attention to safety can result in accident, personal injury, reduction of efficiency and worst of all—loss of life. Watch for safety hazards and correct deficiencies promptly. Use the following safety precautions as a general guide to safe operations when using this machine. Additional safety precautions are used throughout this manual for specific operating and maintenance procedures. Read this manual and review the safety precautions often until you know the limitations.

1. Read the Operator's Manual. Failure to read the Operator's Manual is considered a misuse of this equipment.
2. Become familiar with all the machine's controls and all the caution, warning and danger decals affixed to the machine before attempting to start or operate.
3. Before starting or operating the machine, make a walk around inspection and check for obvious defects such as loose mounting bolts and damaged components. Correct any deficiency before starting.
4. Do not allow children to operate the implement. Do not allow adults to operate it without proper instruction.
5. Do not carry passengers.
6. Keep the area of operation clear of all persons, particularly small children and pets. The operator should cease operation whenever anyone comes within the area.
7. Lower implement to ground, stop tractor engine and apply parking brake before leaving the tractor.
8. Keep hands and feet away from implement.
9. Wear personal protective equipment such as, but not limited to, protection for eyes, ears, feet, hands and head when operating or repairing the equipment. Do not wear loose clothing or jewelry that may catch on equipment moving parts.
10. When performing adjustments or maintenance on the implement, first lower it to the ground or block it securely at a workable height.
11. Never stand between tractor and implement while tractor is being backed to the hitch.
12. Reduce speed when transporting implement to avoid bouncing and momentary loss of steering.
13. Use tractor flashing warning lights, day or night, when transporting implement on road or highways unless prohibited by law.
14. It is recommended that tractor be equipped with Rollover Protective System (ROPS) and seat belt be used in all implement operations.

IMPORTANT FEDERAL LAWS AND REGULATIONS* CONCERNING EMPLOYERS, EMPLOYEES AND OPERATIONS.

*(This section is intended to explain in broad terms the concept and effect of the following federal laws and regulations. It is not intended as a legal interpretation of the laws and should not be considered as such).

U.S. Public Law 91-596 (The Williams-Steiger Occupational and Health Act of 1970) OSHA

This Act Seeks:

“...to assure so far as possible every working man and woman in the nation safe and healthful working conditions and to preserve our human resources...”

DUTIES

Sec. 5 (a) Each employer—

- (1) shall furnish to each of his employees employment and a place of employment which are free from recognized hazards that are causing or are likely to cause death or serious physical harm to his employees;
- (2) shall comply with occupational safety and health standards promulgated under this Act.
- (b) Each employee shall comply with occupational safety and health standards and all rules, regulations and orders issued pursuant to this Act which are applicable to his own actions and conduct.

OSHA Regulations

Current OSHA regulations state in part: “At the time of initial assignment and at least annually thereafter, the employer shall instruct every employee in the safe operation and servicing of all equipment with which the employee is, or will be involved.” These will include (but are not limited to) instructions to:

- Keep all guards in place when the machine is in operation;
- Permit no riders on equipment;
- Stop engine, disconnect the power source, and wait for all machine movement to stop before servicing, adjusting, cleaning or unclogging the equipment, except where the machine must be running to be properly serviced or maintained, in which case the employer shall instruct employees as to all steps and procedures which are necessary to safely service or maintain the equipment.
- Make sure everyone is clear of machinery before starting the engine, engaging power, or operating the machine.

Child Labor Under 16 Years Old

Some regulations specify that no one under the age of 16 may operate power machinery. It is your responsibility to know what these regulations are in your own area or situation. (Refer to U.S. Dept. of Labor, Employment Standard Administration, Wage & Home Division, Child Labor Bulletin #102.)

EMPLOYEE TRACTOR OPERATING INSTRUCTIONS:

1. Securely fasten your seat belt if the tractor has a ROPS.
2. Where possible, avoid operating the tractor near ditches, embankments, and holes.
3. Reduce speed when turning, crossing slopes, and on rough, slick, or muddy surfaces.
4. Stay off slopes too steep for safe operation.
5. Watch where you are going, especially at row ends, on roads, and around trees.
6. Do not permit others to ride.
7. Operate the tractor smoothly - no jerky turns, starts, or stops.
8. Hitch only to the drawbar and hitch points recommended by tractor manufacturers.
9. When tractor is stopped, set brakes securely and use park lock if available.

OPERATION

DURING BLADE ADJUSTMENT KEEP BODY, HANDS AND FEET CLEAR OF BLADE.

ATTACHMENT TO TRACTOR

The box blade should be placed on level ground. Place the tractor 3 point lift arm control in “position control” (non-floating) for attaching and detaching the rear mounted blade. “Draft control” or “position control” can be used while operating. Attach the top link to the top hitch mount and adjust so that the blade frame will be level in the operating position.

Back the tractor until the ends of the lift arms can be attached to the bottom clevis pins on the implement. Secure the lift arms to the clevis pins. (Figure 1)

DETACHING FROM TRACTOR

Lower the blade to the ground with 3 point lift arm control in position control. Remove top link from top hitch mount, disconnect hitch arms from bottom clevis pins and pull tractor away from blade.

OPERATION

LOWER THE BLADE AS MUCH AS POSSIBLE AND SECURELY SUPPORT BEFORE MAKING ANY ADJUSTMENT.

Level the box blade from side to side and front to rear using adjustments on the tractor’s 3-point lift.

To adjust the scarifier shanks, first remove the pins holding the shanks in place. Slide the shanks up or down to desired position and replace the pins. The scarifiers should be adjusted to the lowest position to penetrate and break up the surface when moving large volumes of soil. When leveling, the tips should be positioned to barely chip the surface, and when smoothing, the tips should completely clear the ground.

Care should be exercised during use of the box blade to prevent hanging the scarifier points or the blades on immovable objects or otherwise use the implement under conditions beyond its designed capacity.

TRANSPORTATION

WHEN EQUIPMENT IS TRANSPORTED, USE NECESSARY DEVICES REQUIRED BY LOCAL REGULATIONS FOR ADEQUATE WARNING TO OPERATORS OF OTHER VEHICLES.

MAINTENANCE

Inspect your box scraper periodically and replace any worn or broken parts in order to have it ready for use when needed.

Keep all blade nuts and bolts tightened to 175 ft. lbs.

Blades can be reversed to use opposite cutting edge when needed. (Figures 2 & 3)

Worn scarifier tips may be replaced by grinding or torching off the old tips and welding on replacements.

Store the box blade out of the weather when it is not in use. This helps prevent rusting of the blades and other components.

TORQUE SPECIFICATIONS

Proper torque for American fasteners used

WRENCH SIZE	BOLT AND THREAD SIZE	SAE GRADE 2	SAE GRADE 5	SAE GRADE 8
7/16	1/4 - 20 UNC	6 (7)	8 (11)	12 (16)
7/16	1/4 - 28 UNF	6 (8)	10 (13)	14 (18)
1/2	5/16 - 18 UNC	11 (15)	17 (23)	25 (33)
1/2	5/16 - 24 UNF	13 (17)	19 (26)	27 (37)
9/16	3/8 - 16 UNC	20 (27)	31 (42)	44 (60)
9/16	3/8 - 24 UNF	23 (31)	35 (47)	49 (66)
5/8	7/16 - 14 UNC	32 (43)	49 (66)	70 (95)
5/8	7/16 - 20 UNF	36 (49)	55 (75)	78 (106)
3/4	1/2 - 13 UNC	49 (66)	76 (103)	106 (144)
3/4	1/2 - 20 UNF	55 (75)	85 (115)	120 (163)
7/8	9/16 - 12 UNC	70 (95)	109 (148)	153 (207)
7/8	9/16 - 18 UNF	79 (107)	122 (165)	172 (233)
15/16	5/8 - 11 UNC	97 (131)	150 (203)	212 (287)
15/16	5/8 - 18 UNF	110 (149)	170 (230)	240 (325)
1-1/8	3/4 - 10 UNC	144 (195)	266 (360)	376 (509)
1-1/8	3/4 - 16 UNF	192 (260)	297 (402)	420 (569)
1-5/16	7/8 - 9 UNC	166 (225)	430 (583)	606 (821)
1-5/16	7/8 - 14 UNF	184 (249)	474 (642)	668 (905)
1-1/2	1 - 8 UNC	250 (339)	644 (873)	909 (1232)
1-1/2	1 - 12 UNF	274 (371)	705 (955)	995 (1348)
1-1/2	1 - 14 UNF	280 (379)	721 (977)	1019 (1381)
1-11/16	1-1/8 - 7 UNC	354 (480)	795 (1077)	1288 (1745)
1-11/16	1-1/8 - 12 UNF	397 (538)	890 (1206)	1444 (1957)
1-7/8	1-1/4 - 7 UNC	500 (678)	1120 (1518)	1817 (2462)
1-7/8	1-1/4 - 12 UNF	553 (749)	1241 (1682)	2013 (2728)
2-1/16	1-3/8 - 6 UNC	655 (887)	1470 (1992)	2382 (3228)
2-1/16	1-3/8 - 12 UNF	746 (1011)	1672 (2266)	2712 (3675)
2-1/4	1-1/2 - 6 UNC	870 (1179)	1950 (2642)	3161 (4283)
2-1/4	1-1/2 - 12 UNF	979 (1327)	2194 (2973)	3557 (4820)

Recommended Torque in Foot Pounds (Newton Meters)

Use 75% of specified value for plated fasteners

Use 85% of specified value for lubricated fasteners

15 Series Box Blade Parts

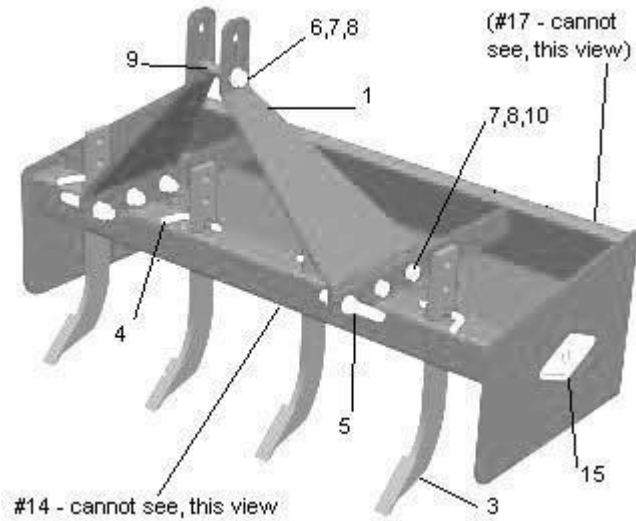

#	Description	BB15-48	BB15-60
1	Top Link Mount	BB15-00-09(L/R)	BB15-00-09(L/R)
2	N/A	N/A	N/A
3	Scarifier Shank	VSCAR	VSCAR
4	1/2 x 3 Pin	VPINO-5000X 5-000	VPINO-5000X 5-000
5	Cat 1 Lift Pin	VLIFTPIN1	VLIFTPIN1
6	3/4" x 5" Gr 5 Bolt	VHBO-750X5- 00NCP	VHBO-750X5- 00NCP
7	3/4" Hex Nut	VHNO-7500NC P	VHNO-7500NC P
8	3/4" Lock Washer	VLWO-7500	VLWO-7500
9	Top Link Spacer	BB20-00-11	BB20-00-11
10	3/4" x 2" Gr 5 Bolt	VHBO-750X2- 00NCP	VHBO-750X2- 00NCP
11	N/A	N/A	N/A
12	N/A	N/A	N/A
13	N/A	N/A	N/A
14	Cutting Edge	VBET154801	VBET156001

15	<i>Brand Label</i>	<i>VLBLS C P R O D U C T S I N C.</i>	<i>VLBLS C P R O D U C T S I N C.</i>
16	<i>Serial # Label</i>	<i>VLBLBBS/N</i>	<i>VLBLBBS/N</i>
17	<i>Product Label</i>	<i>VLBLBB1548</i>	<i>VLBLBB1560</i>

20 Series Box Blade Parts

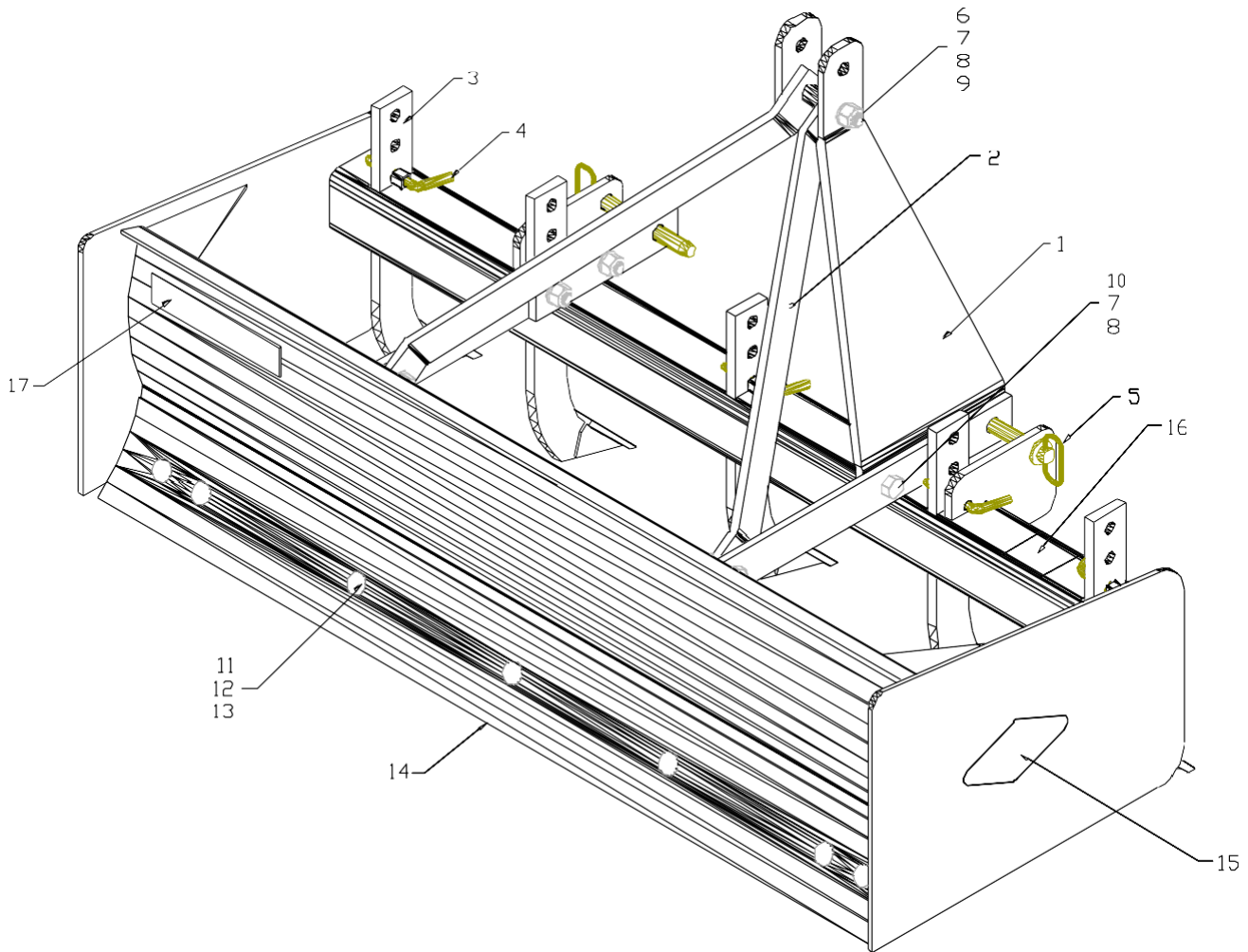

#	Description	BB20-48	BB20-60	BB20-72
1	Top Link Mount	BB20-00- 09(L/R)	BB20-00- 09(L/R)	BB20-00- 09(L/R)
2	Top Link Brace	BB20-00-08	BB20-00-08	BB20-00-08
3	Scarifier Shank	DVSCAR	DVSCAR	DVSCAR
4	1/2 x 3 Pin	VPINO-5000X 5-000	VPINO-5000X 5-000	VPINO-5000X 5-000
5	7/8" Clevis Pin	VPINO-875X4- 25	VPINO-875X4- 25	VPINO-875X4- 25
6	3/4" x 5" Gr 5 Bolt	VHBO-750X5- 00NCP	VHBO-750X5- 00NCP	VHBO-750X5- 00NCP
7	3/4" Hex Nut	VHNO-7500NC P	VHNO-7500NC P	VHNO-7500NC P
8	3/4" Lock	VLWO-7500	VLWO-7500	VLWO-7500

	<i>Washer</i>			
9	<i>Top Link Spacer</i>	<i>BB20-00-11</i>	<i>BB20-00-11</i>	<i>BB20-00-11</i>
10	<i>3/4" x 2" Gr 5 Bolt</i>	<i>VHBO-750X2- 00NCP</i>	<i>VHBO-750X2- 00NCP</i>	<i>VHBO-750X2- 00NCP</i>
11	<i>5/8" Plow Bolt</i>	<i>VPBO-625X1-5 ONCB</i>	<i>VPBO-625X1-5 ONCB</i>	<i>VPBO-625X1-5 ONCB</i>
12	<i>5/8" Hex Nut</i>	<i>VHNO-6250NC P</i>	<i>VHNO-6250NC P</i>	<i>VHNO-6250NC P</i>
13	<i>N/A</i>	<i>N/A</i>	<i>N/A</i>	<i>N/A</i>
14	<i>Cutting Edge</i>	<i>VBE004801</i>	<i>VBE006001</i>	<i>VBE007201</i>
15	<i>Brand Label</i>	<i>VLBLS PRODUCTS INC.</i>	<i>VLBLS PRODUCTS INC.</i>	<i>VLBLS PRODUCTS INC.</i>
16	<i>Serial # Label</i>	<i>VLBLBBS/N</i>	<i>VLBLBBS/N</i>	<i>VLBLBBS/N</i>
17	<i>Product Label</i>	<i>VLBLBB2048</i>	<i>VLBLBB2060</i>	<i>VLBLBB2072</i>

30 Series Box Blade Parts

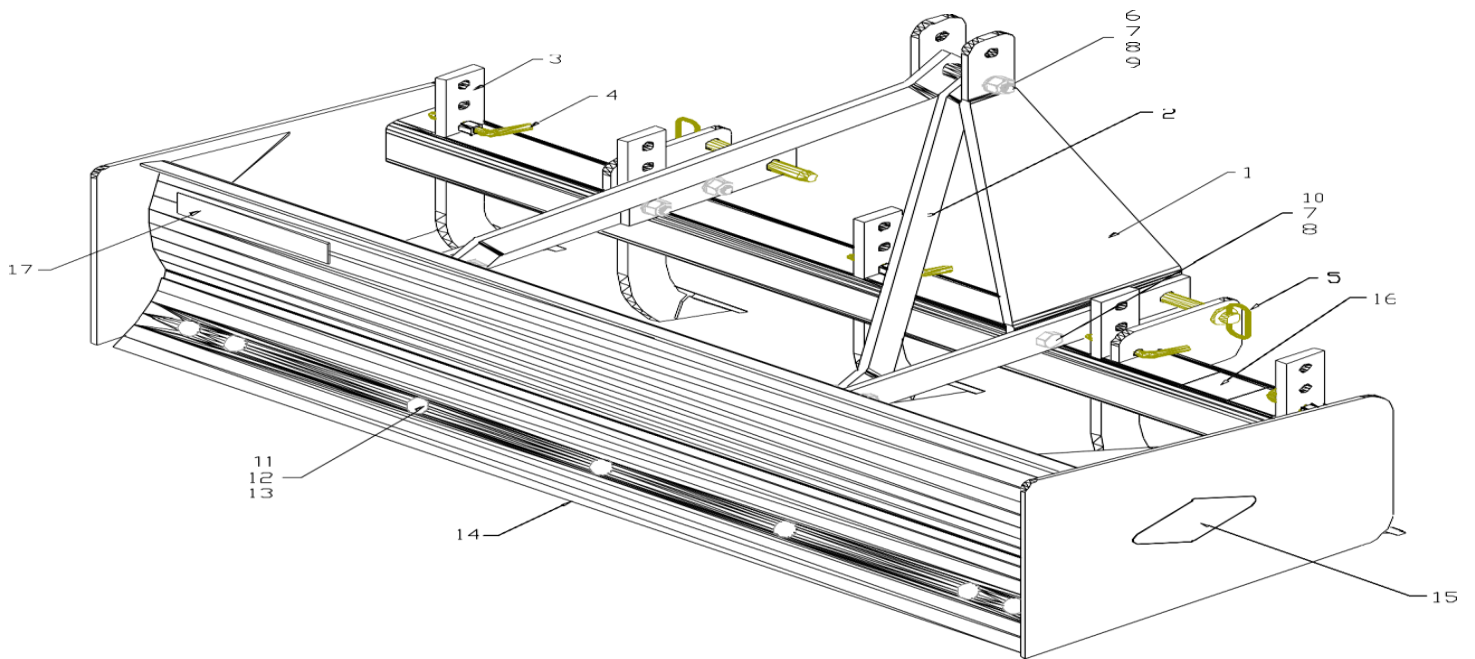

#	Description	BB30-60	BB30-72	BB30-84	BB30-96
1	Top Link Mount	BB30-00-09(L/R)	BB30-00-09(L/R)	BB30-00-09(L/R)	BB30-00-09(L/R)
2	Top Link Brace	BB30-00-08	BB30-00-08	BB30-00-08	BB30-00-08
3	Scarifier Shank	DVSCAR	DVSCAR	DVSCAR	DVSCAR
4	1/2 x 3 Pin	VPINO-5000X 5-000	VPINO-5000X 5-000	VPINO-5000X 5-000	VPINO-5000X 5-000
5	7/8" Clevis Pin	VPINO-875X4- 25	VPINO-875X4- 25	VPINO-875X4- 25	VPINO-875X4- 25
6	3/4" x 5" Gr 5 Bolt	VHBO-750X5- 00NCP	VHBO-750X5- 00NCP	VHBO-750X5- 00NCP	VHBO-750X5- 00NCP
7	3/4" Hex Nut	VHNO-7500NC P	VHNO-7500NC P	VHNO-7500NC P	VHNO-7500NC P
8	3/4" Lock Washer	VLWO-7500	VLWO-7500	VLWO-7500	VLWO-7500
9	Top Link Spacer	BB30-00-11	BB30-00-11	BB30-00-11	BB30-00-11
10	3/4" x 2" Gr 5 Bolt	VHBO-750X2- 00NCP	VHBO-750X2- 00NCP	VHBO-750X2- 00NCP	VHBO-750X2- 00NCP
11	5/8" Plow Bolt	VPBO-625X1-7 5NCB	VPBO-625X1-7 5NCB	VPBO-625X1-7 5NCB	VPBO-625X1-7 5NCB
12	5/8" Hex Nut	VHNO-6250NC P	VHNO-6250NC P	VHNO-6250NC P	VHNO-6250NC P
13	N/A	N/A	N/A	N/A	N/A
14	Cutting Edge	VBEO06001	VBEO07201	VBEO08401	VBEO09601
15	Brand Label	VLBLKIOTI	VLBLKIOTI	VLBLKIOTI	VLBLKIOTI
16	Serial # Label	VLBLBBS/N	VLBLBBS/N	VLBLBBS/N	VLBLBBS/N
17	Product Label	VLBLBB3060	VLBLBB3072	VLBLBB3084	VLBLBB3096